

# 2000 Gal. Two Compartment Septic Tank

FLXX®

FLXX®

- Monolithic tank meets ASTM-C-1227 Spec. for water and waste-water structures.
- Butyl rubber sealant meets Fed. Spec. SS-S-210A. (Provided with tank)
- All plumbing shown in diagram is 4" SDR 35. (Provided with tank)

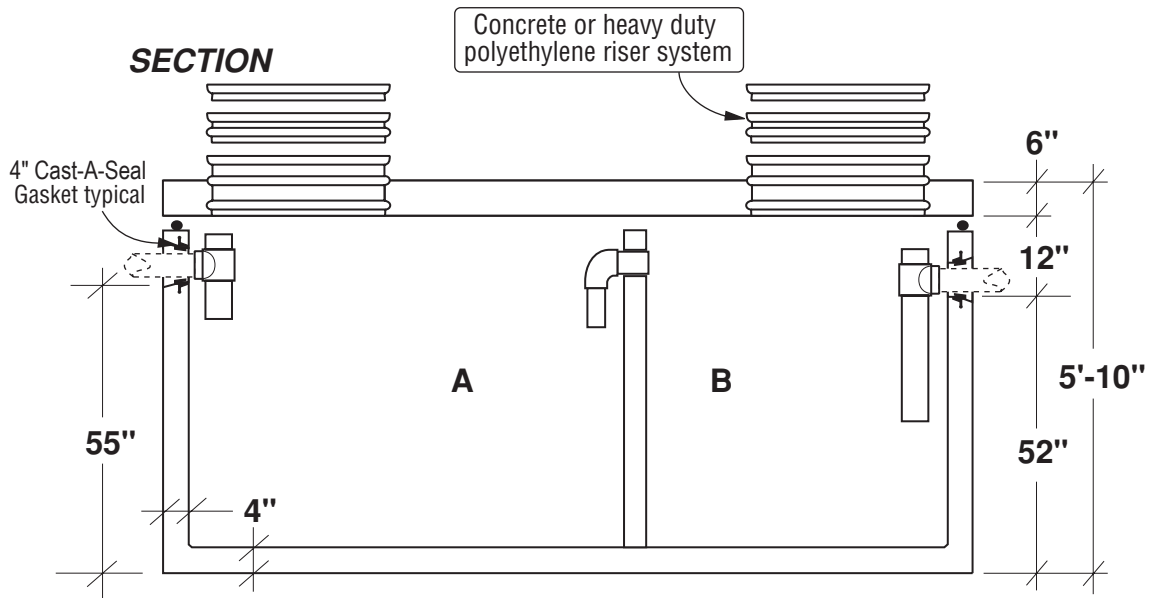
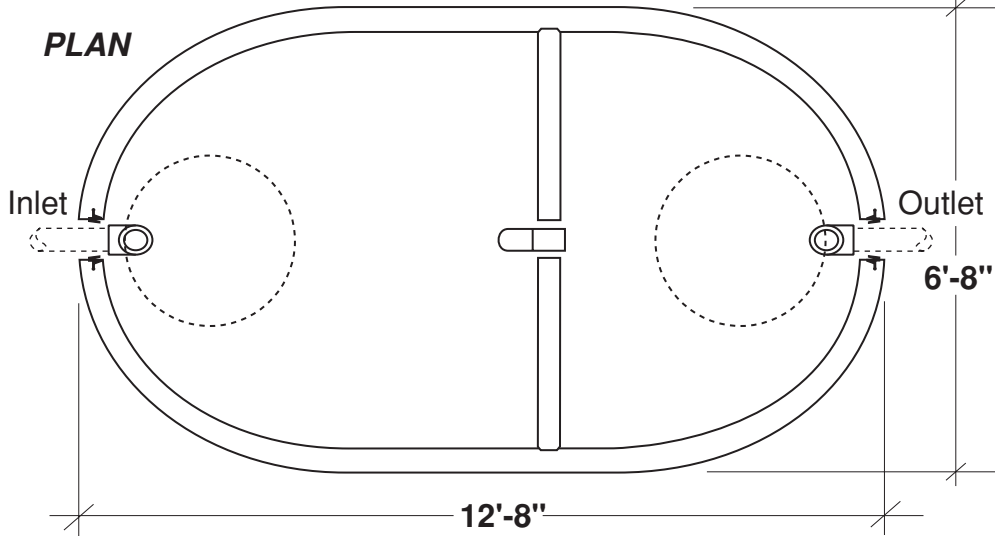

Part #	Capacities (gallons)		Approximate Weights			
	A	B	Tank	Lid	Baffle Wall	Total
PCA-000-258	1200	800	11,690 lbs	5,145 lbs	1,110 lbs	17,945 lbs

Note: N.T.S.

**FLXX®**   
**Watertight**

**Front Range Precast Concrete, Inc.**

5901 Dexter Street, Unit 200, Commerce City, CO 80022  
 Phone (303) 442-3207 • (800) 783-3207 • Fax (303) 442-3209  
[www.flxx.com](http://www.flxx.com)