

# 1500 Gal. Two Compartment Septic Tank

FLXX®

FLXX®

- Monolithic tank meets ASTM-C-1227 Spec. for water and wastewater structures.
- Butyl rubber sealant meets Fed. Spec. SS-S-210A. (Provided with tank)
- All plumbing shown in diagram is 4" SDR 35. (Provided with tank)

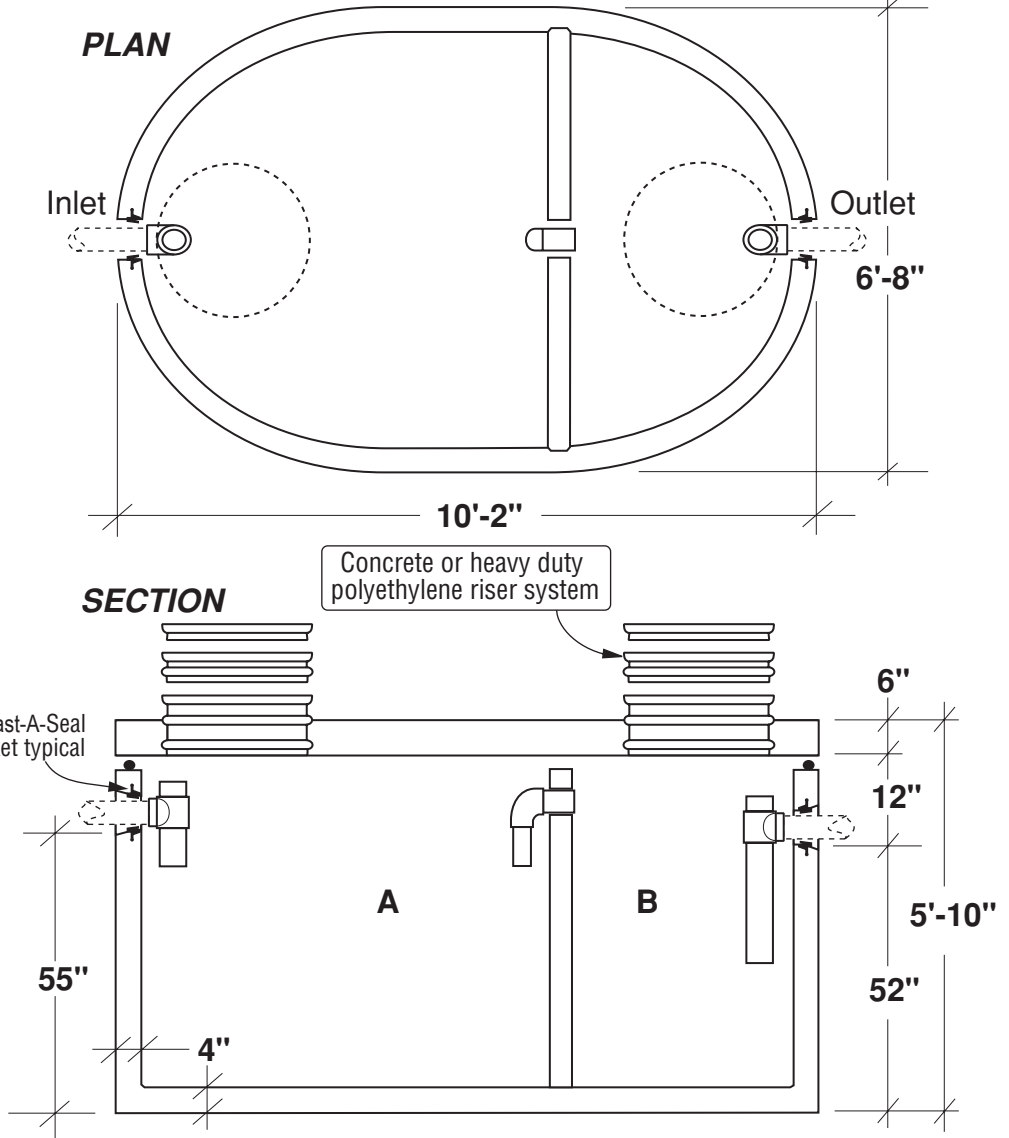

| Part #      | Capacities (gallons) |     | Approximate Weights |           |             |            |
|-------------|----------------------|-----|---------------------|-----------|-------------|------------|
|             | A                    | B   | Tank                | Lid       | Baffle Wall | Total      |
| PCA-000-256 | 920                  | 615 | 9,615 lbs           | 3,900 lbs | 1,110 lbs   | 14,625 lbs |

Note: N.T.S.

**FLXX®**   
**Watertight**  
**Front Range Precast Concrete, Inc.**  
 5901 Dexter Street, Unit 200, Commerce City, CO 80022  
 Phone (303) 442-3207 • (800) 783-3207 • Fax (303) 442-3209  
[www.flxx.com](http://www.flxx.com)