

1250 Gal. Two Compartment Septic Tank

FLXX®

FLXX®

- Monolithic tank meets ASTM-C-1227 Spec. for water and wastewater structures. **PLAN**
- Butyl rubber sealant meets Fed. Spec. SS-S-210A. (Provided with tank)
- All plumbing shown in diagram is 4" SDR 35. (Provided with tank)

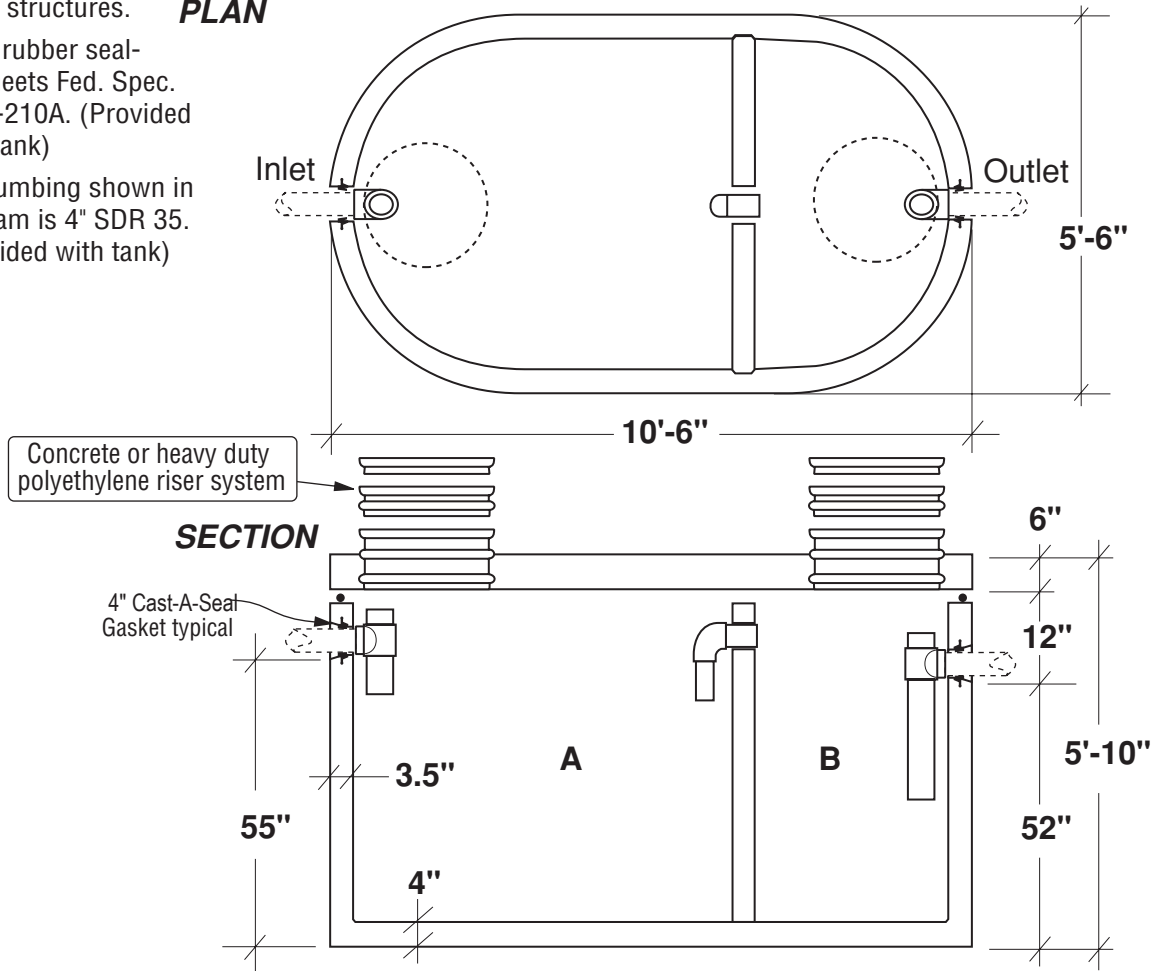

Part #	Capacities (gallons)		Approximate Weights			
	A	B	Tank	Lid	Baffle Wall	Total
PCA-000-254	835	555	8,430 lbs	3,370 lbs	910 lbs	12,710 lbs

Note: N.T.S.

FLXX® 
Watertight
Front Range Precast Concrete, Inc.
 5901 Dexter Street, Unit 200, Commerce City, CO 80022
 Phone (303) 442-3207 • (800) 783-3207 • Fax (303) 442-3209
www.flxx.com