

# 3250 Gal. Sand & Oil Interceptor

FLXX®

FLXX®

**Total Capacity: 3365 gallons**

- Secondary chamber volume equal to 1/3 total capacity.
- Tanks meet or exceed ASTM-C-913 specifications for water and wastewater structures.
- Butyl rubber sealant meets or exceeds Fed. Spec. SS-S-210A. (Provided with tank)
- ASSHTO H-20 traffic rated.
- Plumbing provided by others.

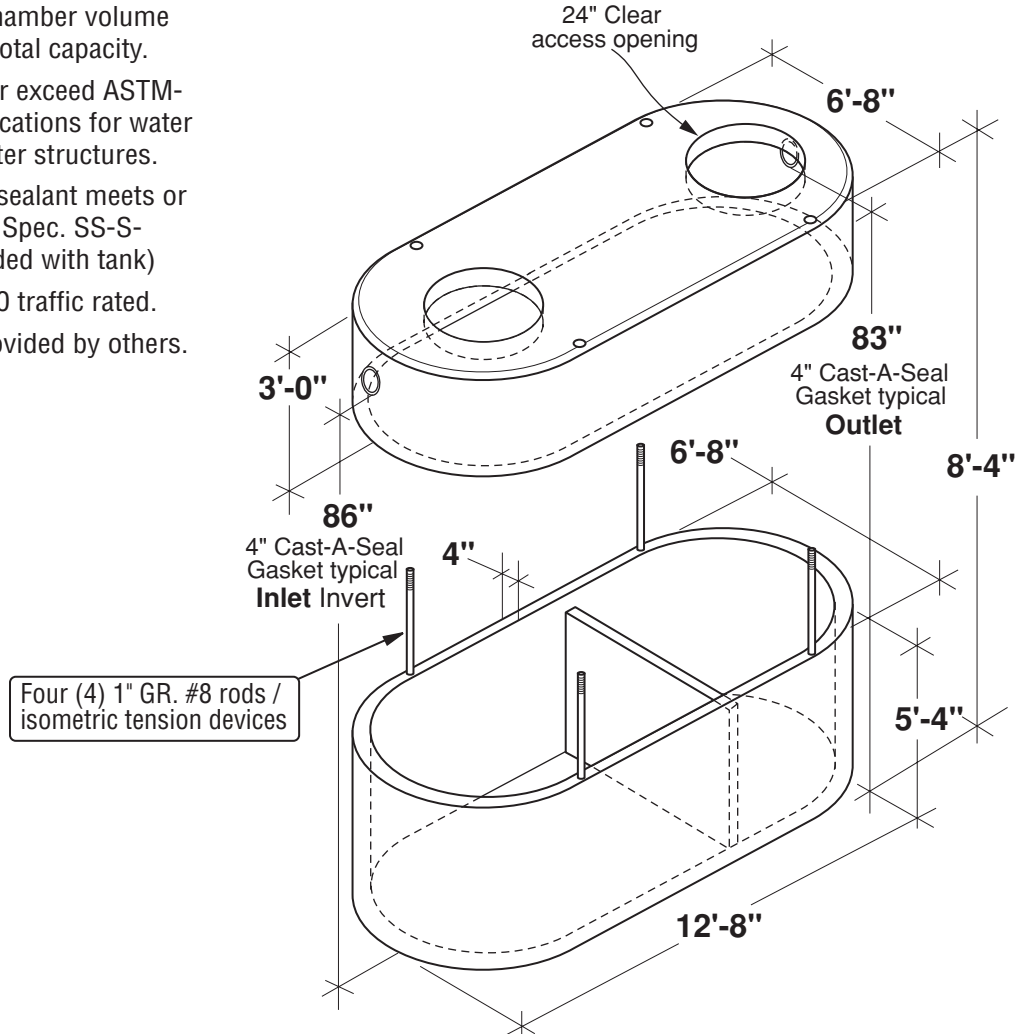

Part #	Capacities				Approximate Weights			
	Section/Gal.		Cubic Ft.		Tank	Lid	Baffle Wall	Total
PCA-000-321	<b>A</b>	<b>B</b>	<b>A</b>	<b>B</b>	11,690 lbs	7,715 lbs	1,110 lbs	20,515 lbs
	1940	1300	253	170				

Note: N.T.S.

**FLXX®**   
**Watertight**  
**Front Range Precast Concrete, Inc.**  
 5901 Dexter Street, Unit 200, Commerce City, CO 80022  
 Phone (303) 442-3207 • (800) 783-3207 • Fax (303) 442-3209  
[www.flxx.com](http://www.flxx.com)