

400 Gal. Grease Interceptor

FLXX®

FLXX®

- PCA-000-331
- Secondary chamber volume equal to 1/2 total capacity.
- **Verify compliance with local regulations.**
- Tanks meet or exceed ASTM-C-478 specifications for water and wastewater structures.
- Butyl rubber sealant meets or exceeds Fed. Spec. SS-S-210A. (Provided with tank)
- ASSHTO H-20 traffic rated.
- Plumbing provided by others.

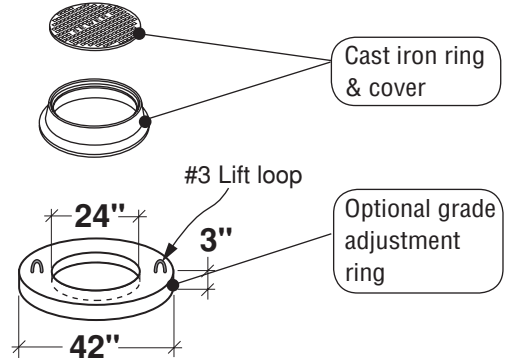

TOP VIEW

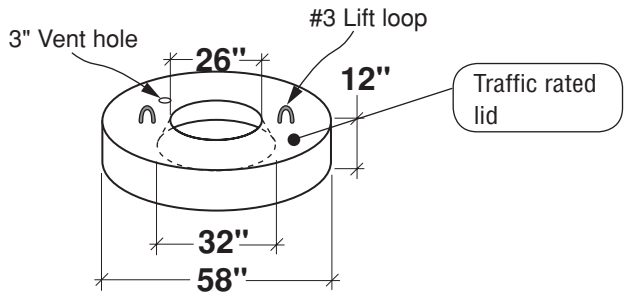
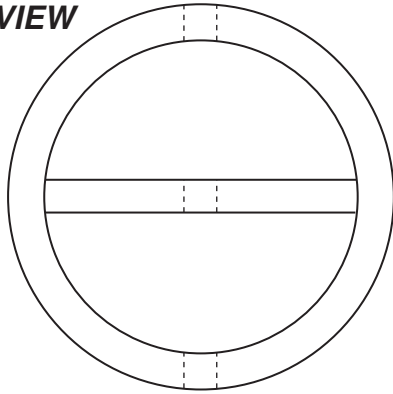

BAFFLE

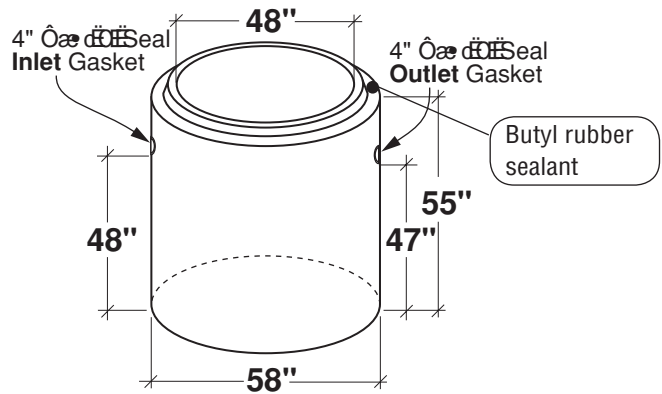
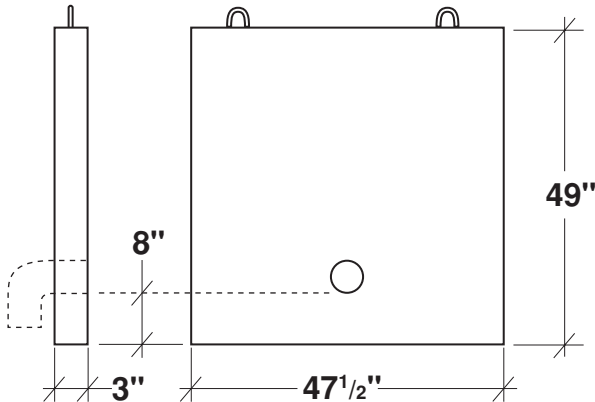

Note: N.T.S.

FLXX® 
 Watertight

Front Range Precast Concrete, Inc.

1 Jefferson Avenue, Aurora, Colorado 80011 • (303) 442-3207 • (800) 783-3207 • Fax (303) 442-3209
 www.flxx.com