

1000 Gal. Electric Lift Station

FLXX

FLXX

- Monolithic tank meets ASTM-C-1227 Spec. for water and wastewater structures.
- Butyl rubber sealant meets Fed. Spec. SS-S-210A. (Provided with tank)
- All plumbing shown in diagram is 4" SDR 35. (Provided with tank)

PLAN

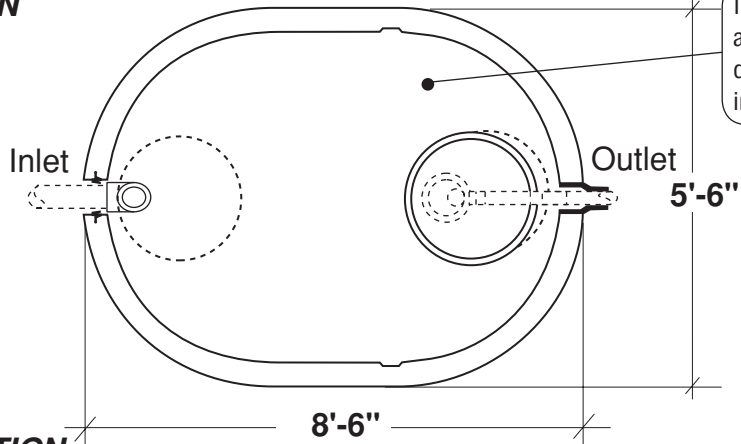

SECTION

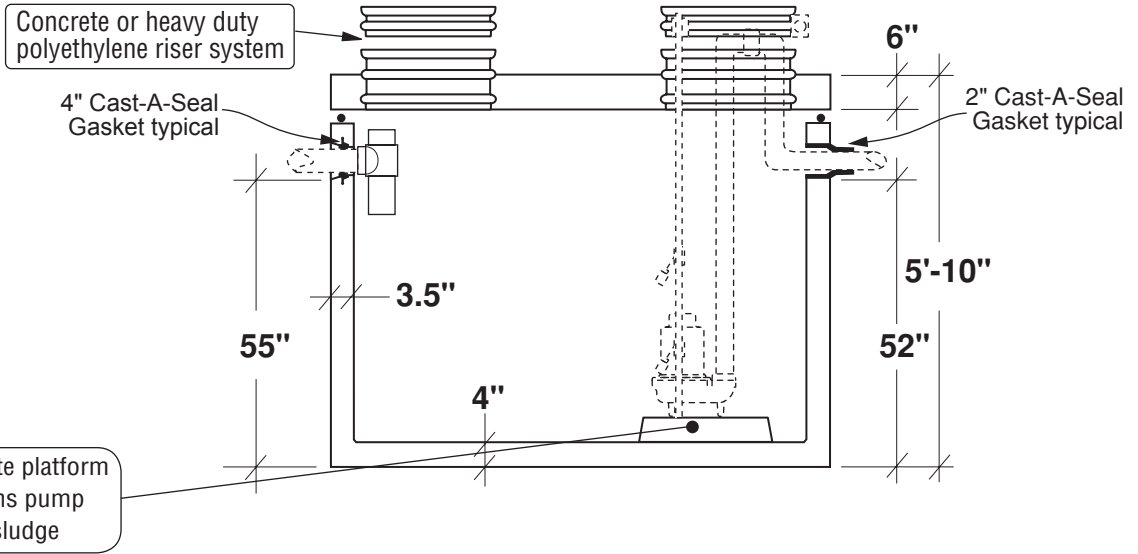

Part #	Discharge / Cycle	Approximate Weights		
		Tank	Lid	Total
PCA-000-298	21.5 Gal/Vertical Inch	6,710 lbs	2,550 lbs	9,260 lbs

Note: N.T.S.

FLXX 
Watertight
Front Range Precast Concrete, Inc.
 5901 Dexter Street, Unit 200, Commerce City, CO 80022
 Phone (303) 442-3207 • (800) 783-3207 • Fax (303) 442-3209
www.flxx.com