

500 Gal. Single Auto Siphon Chamber

FLXX®

FLXX®

- Monolithic tank meets ASTM-C-1227 Spec. for water and wastewater structures.
- Butyl rubber sealant meets Fed. Spec. SS-S-210A. (Provided with tank)
- All plumbing shown in diagram is 4" SDR 35. (Provided with tank)

PLAN

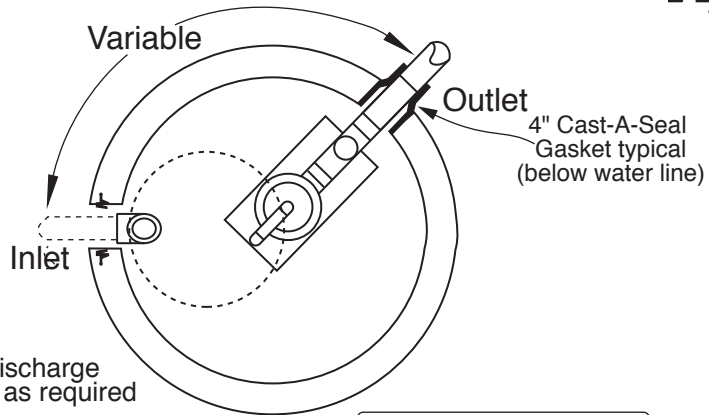

Angle of Inlet/Discharge variable on site as required

SECTION

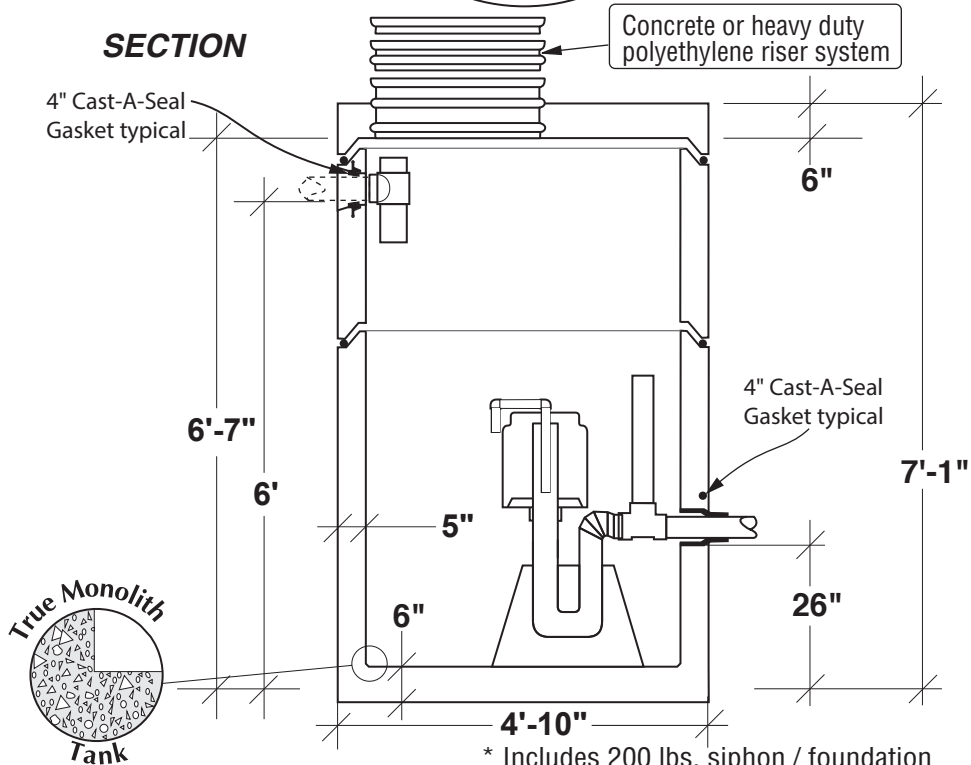

* Includes 200 lbs. siphon / foundation

Part #	Siphon / Discharge		Approximate Weights			
			Bottom Section*	Top Section	Lid	Total
PCA-002-285	#423	180 Gal.	4,540 lbs	1,735 lbs	1,520 lbs	7,795 lbs

Note: N.T.S.

FLXX® 
Watertight

Front Range Precast Concrete, Inc.

5901 Dexter Street, Unit 200, Commerce City, CO 80022
Phone (303) 442-3207 • (800) 783-3207 • Fax (303) 442-3209
www.flxx.com