

400 Gal. Dual Alternating Auto Siphon Chamber

FLXX®

FLXX®

- Monolithic tank meets ASTM-C-1227 Spec. for water and waste-water structures.
- Butyl rubber sealant meets Fed. Spec. SS-S-210A. (Provided with tank)
- All plumbing shown in diagram is 4" SDR 35. (Provided with tank)

PLAN

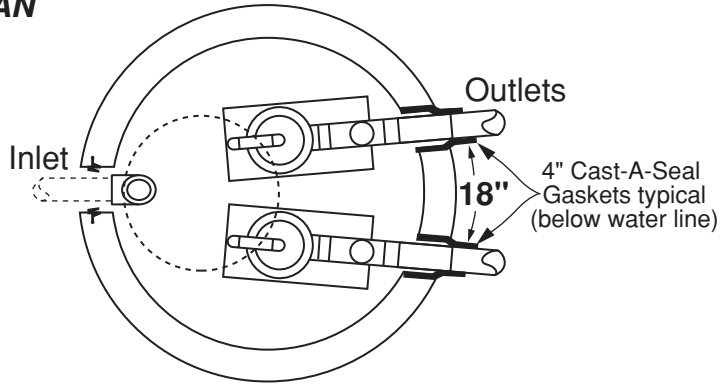

SECTION

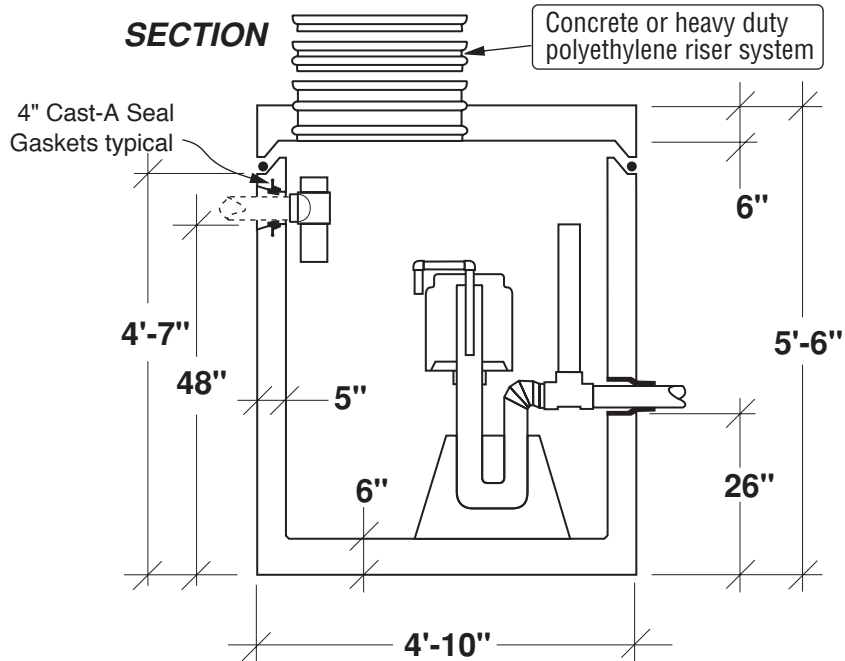

* Includes (2) 200 lbs. siphon / foundations

Part #	Siphon / Discharge		Approximate Weights		
			Tank*	Lid	Total
PCA-000-281	#413	100 Gal.	5,250 lbs	1,520 lbs	6,770 lbs
PCA-001-281	#417	135 Gal.			

Note: N.T.S.

FLXX® 
Watertight

Front Range Precast Concrete, Inc.

5901 Dexter Street, Unit 200, Commerce City, CO 80022
 Phone (303) 442-3207 • (800) 783-3207 • Fax (303) 442-3209

www.fxx.com