

# Polyethylene Risers

FLXX®

FLXX®

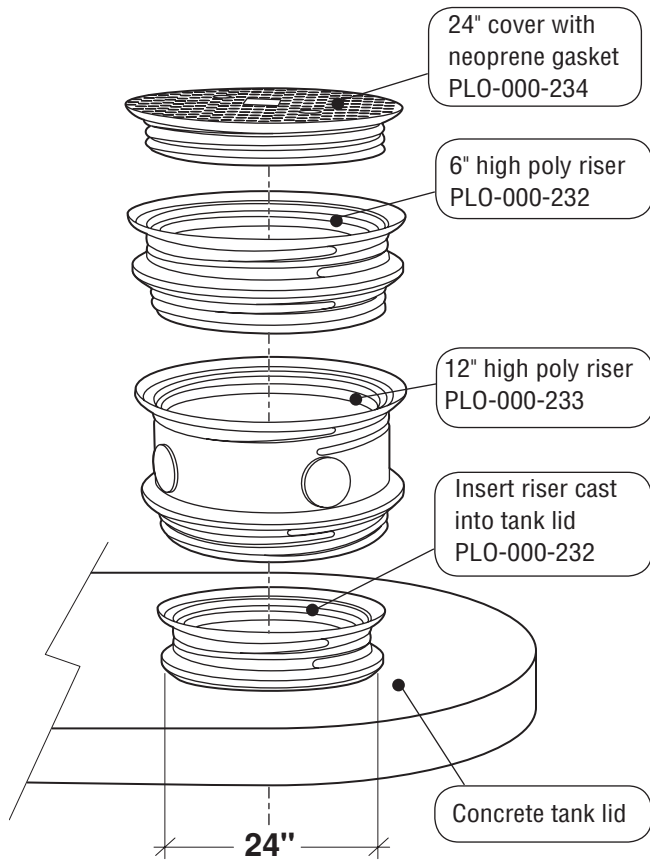

## Transition Risers:

Transition Risers have been developed to allow older septic tanks to convert to lightweight durable polyethylene risers and above grade covers. The concrete base of each transition riser is sealed to the septic tank lid with butyl rubber sealant. Then either 6" or 12" risers are screwed into the base to bring the poly covers up to grade.

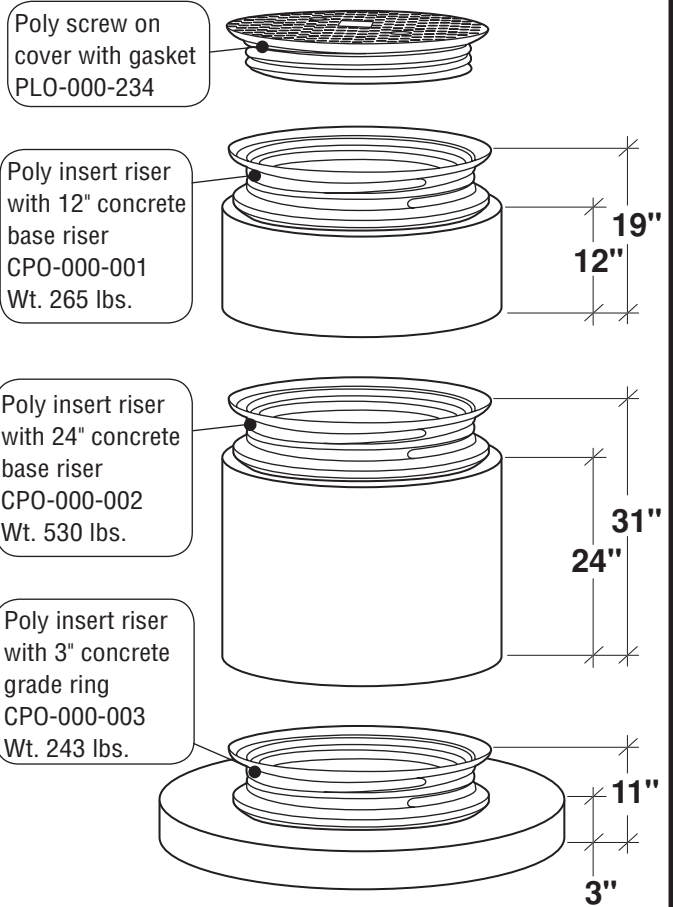

## Cover Can Be Secured

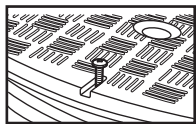

Locate the "Secure Here" hole on the cover and install a tamper resistant screw through the lid and into the riser below.

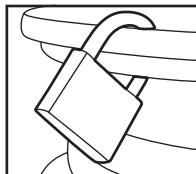

To secure with a padlock, drill a larger hole to accommodate the lock.

Note: N.T.S.

**FLXX®**   
**Watertight**  
**Front Range Precast Concrete, Inc.**  
 5901 Dexter Street, Unit 200, Commerce City, CO 80022  
 Phone (303) 442-3207 • (800) 783-3207 • Fax (303) 442-3209  
[www.flxx.com](http://www.flxx.com)