

INFILTRATOR[®] SYSTEMS INC

Infiltrator Systems Inc. (ISI) is the world's leading manufacturer of plastic leach field drainage chambers for environmental onsite wastewater solutions. A direct replacement for stone and pipe leach fields, these chambers have revolutionized the septic industry. They provide cost-effective, efficient methods for handling residential and commercial wastewater.

These systems are approved in all 50 states and all 10 Canadian provinces with up to a 50% smaller footprint as compared to stone and pipe systems. There are over 1.5 million Infiltrator systems installed and more than 27 million units in-ground in the U.S. and 24 other countries. Infiltrator systems have stood the test of time with a history of performance since 1987. Today, one in four septic systems in the U.S. is an Infiltrator chamber system.

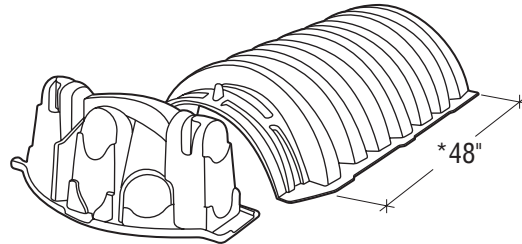

Part #	Description	Capacity
IFR-000-003	Quick 4 Standard Chamber* L52" x W34" x H12" 85 units per pallet	43.5g
IFR-000-302	Quick 4 Standard End Cap	9.16g
IFR-000-004	Quick 4 Equalizer 36 Chamber* L52" x W22" x H12" 170 units per pallet	32.17g
IFR-000-303	Quick 4 Equalizer 36 End Cap	5.57g
IFR-000-005	Quick 4 High Capacity Chamber* L52" x W34" x H16" 75 units per pallet	62.12g
IFR-000-305	Quick 4 High Capacity End Cap	14.41g

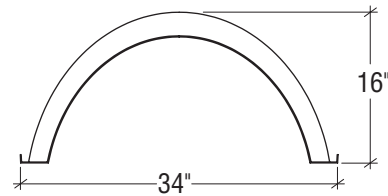
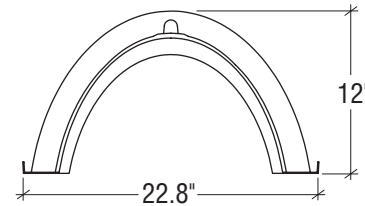
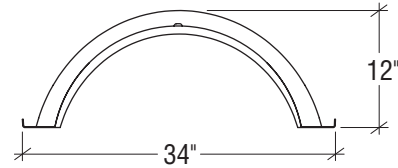

Accessories

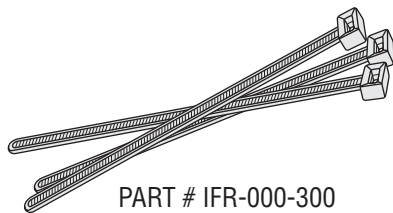

PART # IFR-000-300
24" Chamber Pipe Hangers
(Sold in packs of 50)

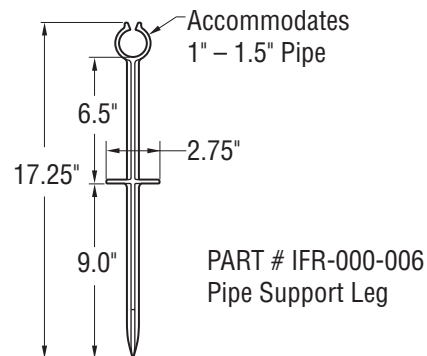

PART # IFR-000-006
Pipe Support Leg

*Note: Effective length is 48" for all Infiltrator Chambers.