

Concrete Risers

FLXX®

FLXX®

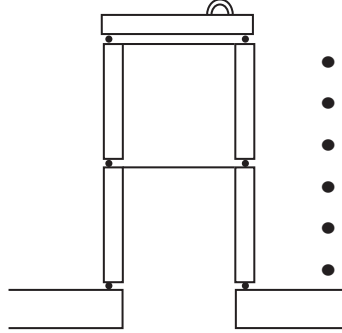
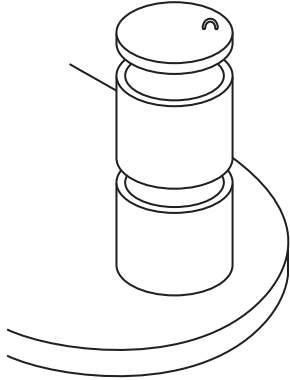

- Sealant at joints as required
- 24" Interior diameter riser
- 12" and 24" heights available
- 3" wall thickness
- 3" x 30" tank riser lid
- Mates with tank access hole

2ø Disk lid
PCO-000-003
Wt. 183 lbs.

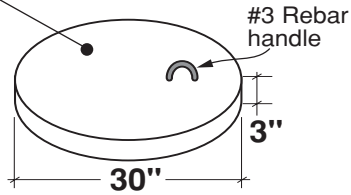

2x1 Riser
PCO-000-006
Wt. 265 lbs.

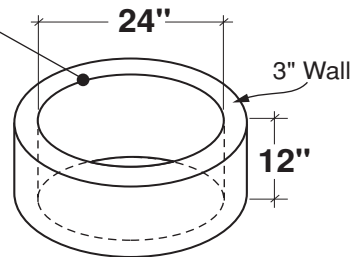

2x2 Riser
PCO-000-007
Wt. 530 lbs.

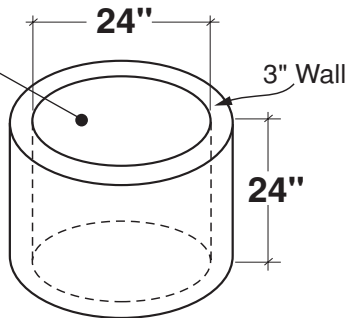

Traffic-rated (H-20) tanks are available.

Use of concrete risers with cast iron frames and cover completes this heavy duty system.

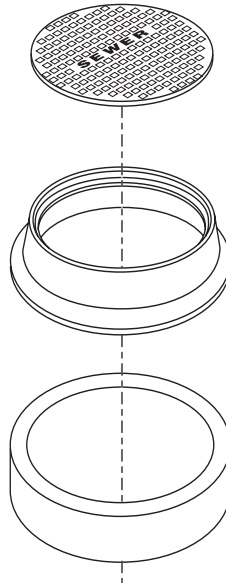

Note: N.T.S.

FLXX® 
Watertight

Front Range Precast Concrete, Inc.

5901 Dexter Street, Unit 200, Commerce City, CO 80022
Phone (303) 442-3207 • (800) 783-3207 • Fax (303) 442-3209
www.flxx.com